



## **ISCARPARTING**

**New Intermediate Holders for  
TANG-F-GRIP and DO-F-GRIP Square Type D82.  
Adapters Designed for all Modular Tooling Systems.**

# ISCARPARTING

## Highlights

**ISCAR is adding new intermediate holders for TANG-F-GRIP and DO-F-GRIP square type D82 adapters, designed for all modular systems and suitable for CNC and multi-spindle machines.**

Following the successful launch of modular adaptations for tool holder systems that can carry ISCAR's MODULAR-GRIP parting adapters (see NPA 46-2016 link) <https://fileshare.ssl.iscar.com/data/public/549eda>, ISCAR has designed new intermediate holders for Tang-F-Grip and Do-F-Grip square type D82 adapters.

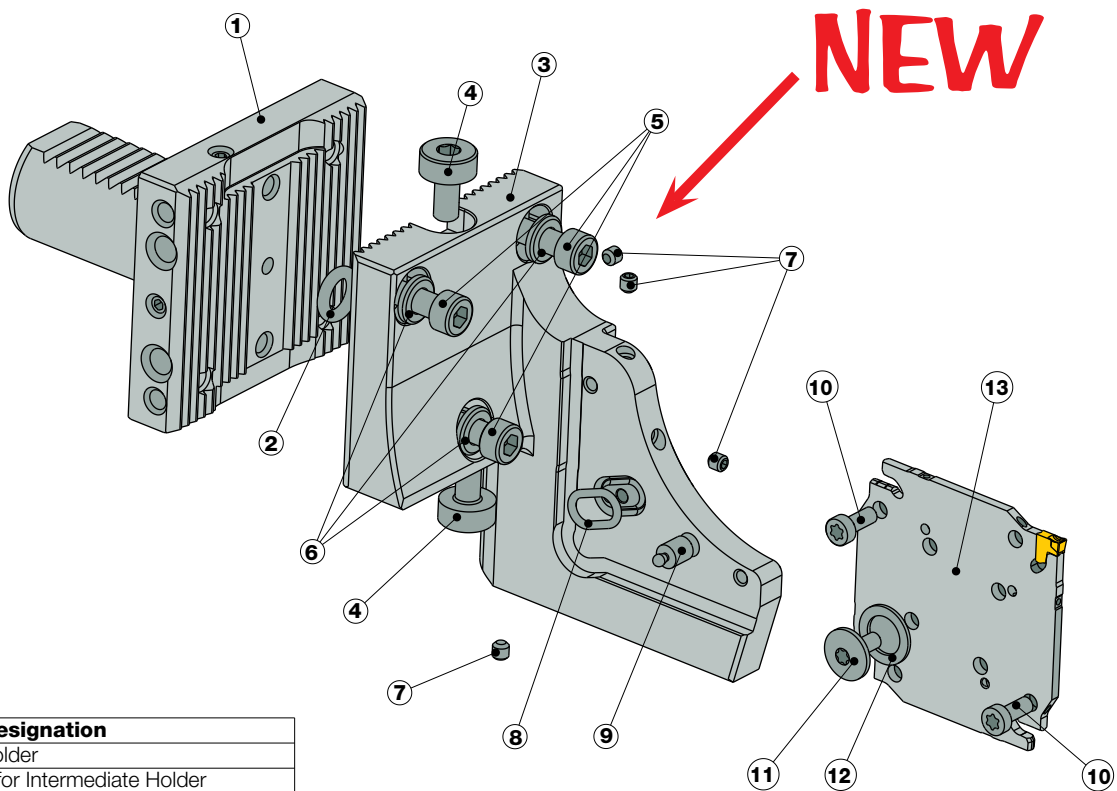

No.	Item Designation
1	Base Holder
2	O-Ring for Intermediate Holder
3	Intermediate Holder
4	Adjustment Screw for Center Height
5	Mounting Screw for Intermediate Holder
6	Washer
7	Sealing Screws For intermediate Holder
8	O-Ring for F Grip Adapter pocket
9	Pin for F Grip Adapter
10	Mounting Screw M4 for F Grip Adapter
11	Sealing Screws M4
12	Sealing Washer
13	F Grip Adapter

# ISCARPARTING

## Features

- An intermediate holder holder with captive adaptation for quad/square type adapters with 4 pockets for 3.23" (82 mm) bar diameters
- Designed to carry the standard TGAQ D82 adapters for TANG-GRIP inserts and DGAQ D82 adapters for DO-GRIP inserts
- Suitable for all standard TANG-GRIP and DO-GRIP inserts in widths of .0787-.197"
- Outstanding stability, vibration-free parting system due to full support under the adapter
- Improved insert life, surface finish, and workpiece straightness due to robust design
- Enables reduction of cutting width due to excellent stability, leading to material savings
- An 3.23" bar can be cut with a very stable .787" Tang-Grip insert
- Guarantees high productivity, especially when using TAG N...HF inserts with feeds of up to .016 ipr
- Economical adapters with 4 pockets
- User friendly, easy to operate
- Saves setup time after pocket replacement - adapter can be positioned in a new pocket with no setup
- The tools and adapters are designed for JET-CUT cooling of up to 2000 PSI, and very efficient when cutting at 100-145 PSI
- Suitable for all type of CNC and suitable for all types of CNC and multi-spindle

## Availability

In stock

## Prices

Your price list will be sent to you by the pricing department and is available in the **GAL** system.

## Order Procedure

European subsidiaries please order directly from IEC.

All other subsidiaries should order from Tefen.

Sincerely,

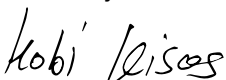

**Kobi Kisos**

Chief Technical Officer,  
Marketing Division  
ISCAR Headquarters

Sincerely,



**Rafi Rabouach**

Director of Product Management  
Grooving, Parting and Turning Applications  
ISCAR Headquarters

Sincerely,



**Kobi Guy**

Product Manager,  
Parting & Slitting, Grip System  
ISCAR Headquarters

# LOGIQ FGRIP

HIGH FEED GRIP HOLDER

## V## SQ#-#-D82-JHP

Intermediate Holders for TANG F GRIP and DO F GRIP Square Type D82 Adapters Designed for Modular Tooling Systems

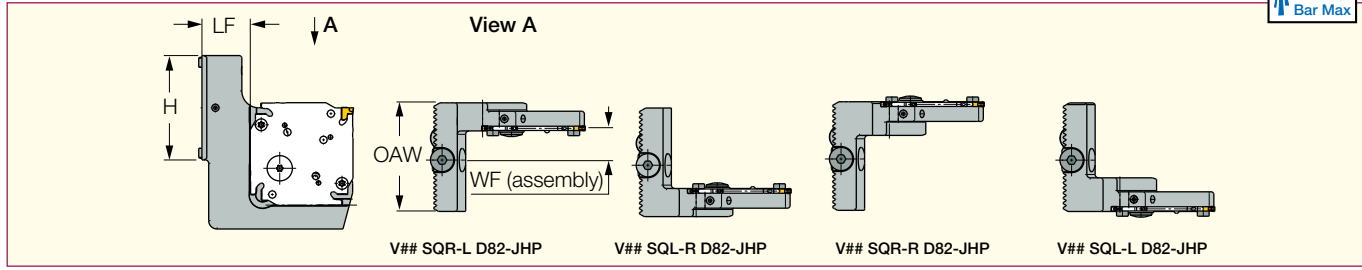

Designation	H	LF	OAW	WF <sup>(1)</sup>
V60 SQL-R/L-D82-JHP *	2.441	1.130	2.539	1.140
V60 SQR-R/L-D82-JHP *	2.441	1.130	2.539	.742
V85 SQL-R/L-D82-JHP *	3.268	1.130	3.346	1.612
V85 SQR-R/L-D82-JHP *	3.268	1.130	3.346	1.077

(1) When .118" width insert is used.

### Identification Key

V60 SQL-L-D82-JHP

V60 SQL-R-D82-JHP

V60 SQR-L-D82-JHP

V60 SQR-R-D82-JHP

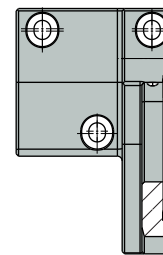
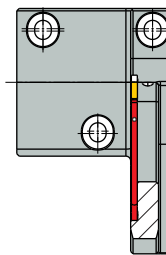
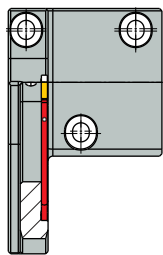
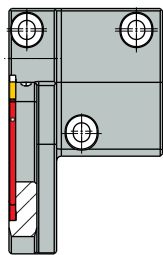
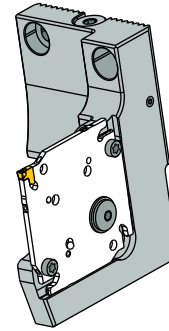
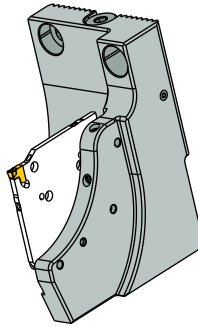
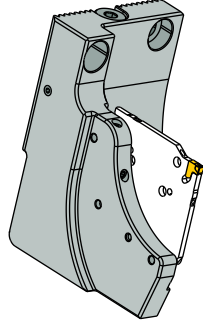
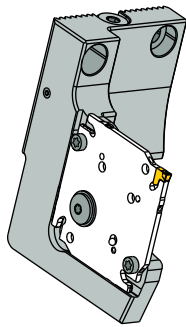

L- Holder (prism) orientation  
L- Pocket side

L- Holder (prism) orientation  
R- Pocket side

R- Holder (prism) orientation  
L- Pocket side

R- Holder (prism) orientation  
R- Pocket side

Designation	Sealing Screw	Seal washer	O-Ring	Pin	Clamp Screw
V## SQ#-#-D82-JHP	SR M4X9-SEAL-JHP	JHP COPPER SEAL 1/8"	O-RING 10X2 NBR	SIDE THRUST PIN 3mm	SR ISO 14580 M4X10